

PARTS LIST

For K-004 Audible Continuity Checker Kit

- 1 of GK27001 8 OHM SPEAKER
- 1 of GK14004 555 IC TIMER CHIP
- 1 of GK18001 TRANSISTOR NPN 2N3904
- 1 of GK35001 9-VOLT BATTERY SNAP
- 1 of GK02012 0.01 MFD DISK CAPACITOR
- 2 of GK01065 1K OHM RESISTORS (BROWN, BLACK, RED, GOLD)
- 1 of GK01017 10 OHM RESISTOR (BROWN, BLACK, BLACK, GOLD)
- 1 of GK01115 120K OHM RESISTOR (BROWN, RED, YELLOW, GOLD)
- 2 of GK45003 WIRES
- 2 of GK46005 ALLIGATOR CLIPS WITH WIRES
- 1 of GK19001 8 PIN IC SOCKET
- 1 of 7004 CIRCUIT BOARD FOR K-004

06-09-2004

Copyright 2004 PracTrak, Inc.

Gibson Tech Ed, Inc.
TECHNOLOGY YOU CAN *BUILD* ON

K-004 AUDIBLE CONTINUITY CHECKER KIT

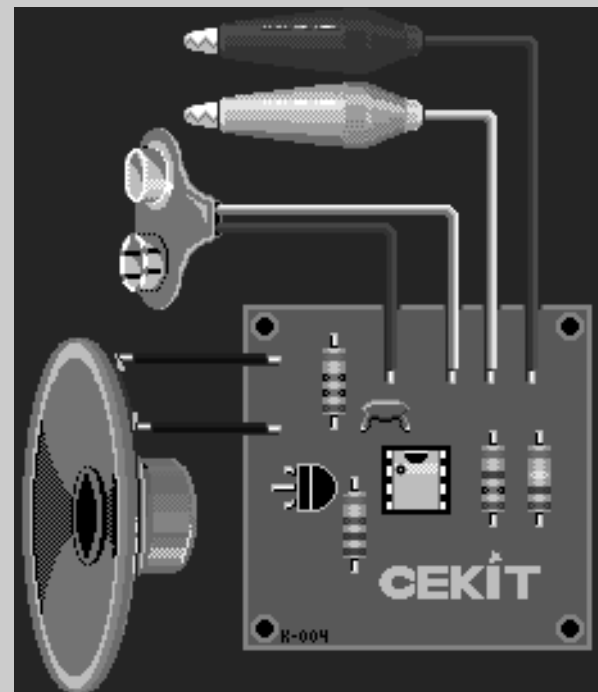

1053 South 1675 West Orem, UT 84058 800-422-1100

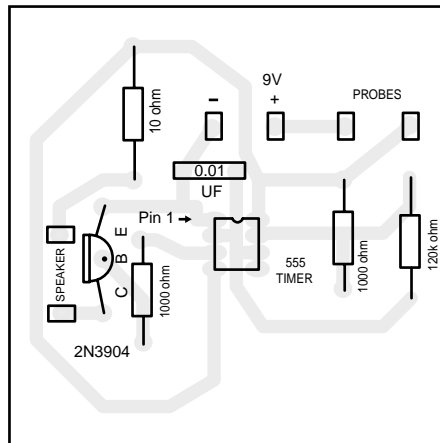
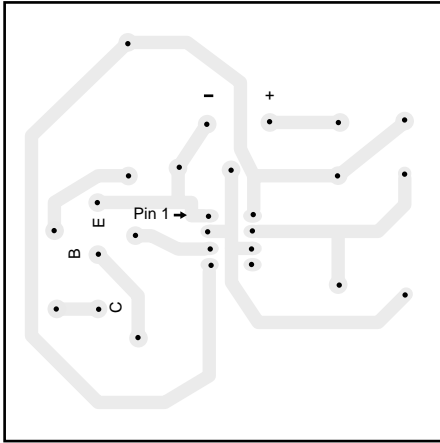

CB LAYOUT OF K-004 AUDIBLE CONTINUITY CHECKER

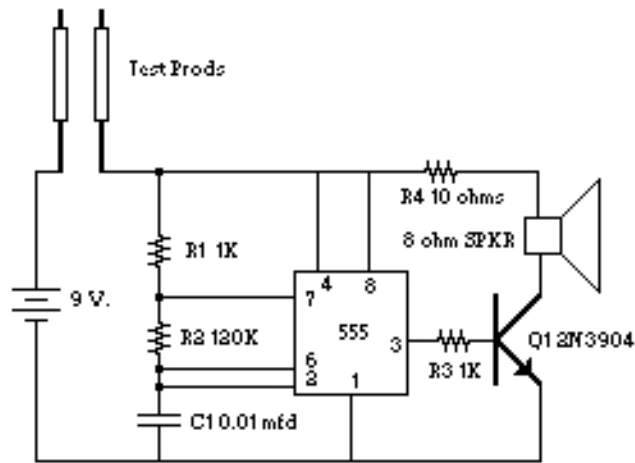

SCHEMATIC DIAGRAM K-004

**SCHEMATIC DIAGRAM FOR KIT K-004
AUDIBLE CONTINUITY CHECKER**

NOTES

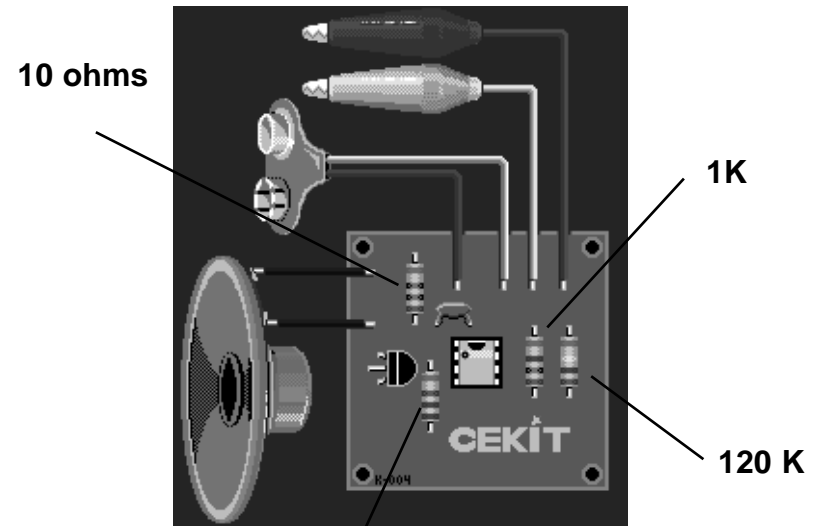

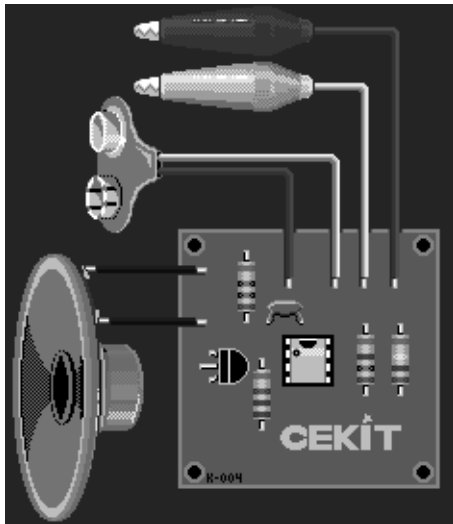

PICTURE OF KIT K-004 AUDIBLE CONTINUITY CHECKER

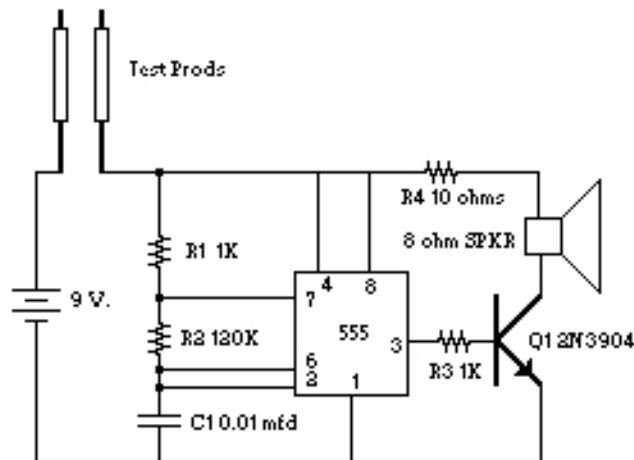

SCHEMATIC DIAGRAM K-004

SCHEMATIC DIAGRAM FOR KIT K-004
AUDIBLE CONTINUITY CHECKER

INTRODUCTION

This K004 Audible Continuity Checker generates a signal in the audible range. It is really generating digital pulses that will cause a speaker to vibrate.

You can use these pulses to test the continuity of speakers, fuses, light bulbs, wires, line cords, capacitors (check to see if they are shorted), switches, transformers, heating elements in stoves, irons, etc.

You can mount this kit in a metal or a plastic box and keep it handy on your workbench or in your tool box. It may surprise you how much you can fix with this simple device.

Theory of Operation

The quantity of pulses per second generated by the 555 Timer IC in this kit is controlled by the value of capacitor C1 and resistors R1 and R2. The smaller the value of C1 in Farads, the more pulses per second. Varying the values of R1 and R2 will also control the quantity of pulses per second.

The speaker converts these pulses into sound. When you connect the prods to a fuse, or any other item you want to check, the speaker will put out a sound if the item is "good." If you hear nothing, then there is no continuity between the clips. Unless the item being tested is a capacitor, this indicates that the component is defective.

Note:

Be careful to remove all power from a circuit that you are testing, i.e., remove the battery or unplug the circuit from the wall socket.

Also, if you are checking resistors or switches 'in-circuit,' you may get erroneous readings. In other words, you may hear the speaker and think that the component is good, when in reality it has found another path through the circuit

STEP BY STEP ASSEMBLY INSTRUCTIONS
for Kit #K-004 AUDIBLE CONTINUITY CHECKER

General Instructions: Be sure that all the soldering is done on the opposite side of the circuit board from where the components are. Push the wires through the holds in the circuit board, bend them a little, and then solder them to the underside of the circuit board. Use a soldering iron of under 60 watts of power to avoid overheating and destroying the electronic components as well as the circuit board.

Some electronic components, including battery snaps, have polarity! This means that they must be in the exact holes in the circuit board. If you put the leads or wires in the wrong holes, the kit will not work. Be sure to watch for components that have polarity.

Step 1 -- Find the 4 resistors, these are the components that have color bands around their circumference. (Be sure to install them on the circuit board in their correct position. Note: They do not have polarity, so it does not matter which 'way' you install them, just be sure to use the two holes assigned to the particular resistor.)

Solder the wires on the resistors to the underside of the circuit board and cut off the extra wire sticking out. Be careful to cut them slowly so that the wire pieces do not fly across the room hitting someone in the eye.

Step 2 -- Find the 8 pin IC socket and put it in the holes for the IC 555. Solder the short wires to the underside of the circuit board. Cut off any excess wires.

Step 3 -- Find the 0.01 disk capacitor and install it on the circuit board. Cut off the excess leads.

Step 4 -- Find the transistor 2N3904. Push the three wire leads through the holes in the circuit board and solder them to the underside. Be sure to orient the plastic transistor case with the flat side away from the center of the circuit board. This component has polarity and must be installed exactly right.

Step 5 -- Find the Speaker and solder wires to the two terminals on the speaker itself. Then solder the ends of these wires into the circuit board. There is no polarity to be observed.

Step 6 -- Find the 9-Volt Battery Snap. Be sure to install the Red wire in the + hole and the black wire in the - hole.

Step 7 -- Find the IC555 Timer and install it into the socket, being sure to put pin 1 of the IC in the hole that has the black dot next to it. This project will not work if you install it backwards. It may also damage the IC if you connect the battery while the IC is installed wrong.

Testing Your Kit

Before you connect the battery, look carefully at all the solder connections to be sure they are good and shiny. Reheat any connections that are loose or are not shiny.

Look at the transistor wires and be sure there are no solder-bridges connecting one wire to another. These short-circuits will cause the project not to work.

If all looks fine, connect the battery and touch the prods together. You will here a sound coming from the speaker. If you do not, disconnect the battery immediately so you do not discharge it completely. If you need help finding the problem, ask your teacher or a friend who knows electronics.

This project should give you many years of good service. You can use it around the house as well as when repairing things for friends. We hope you enjoy it and make electronics your hobby.